

INSTALLATION GUIDE

# MASONRY SYSTEM SURETOUCH



Suretouch™  
by Permacon

SURETOUCH.CA

---

# Table of contents

## Index installation videos

You can see the installation videos of the Suretouch system in our website at [suretouch.ca](http://suretouch.ca)

---

### 1. Corporate Introduction

- 1.1 Characteristics and Advantages of the Products
- 1.2 R13.5 Insulation
- 1.3 Significant Reduction in Heating Costs: 30-42%
- 1.4 Energy-Efficient
- 1.5 Self-Supporting
- 1.6 Sound-Proofing
- 1.7 Water Barriers
- 1.8 CCMC Certification 13302 –R and ICC
- 1.9 Technical Support at all Times

---

### 2. Preparing the Wall

- 2.1 Solid, Flat and Uniform Composition of the Wall
- 2.2 OSB versus Plywood, Tentest, Isoclad and Others
- 2.3 Foundation or Starter Strip?
- 2.4 Air Barrier
- 2.5 Seal Openings Adequately
- 2.6 Entrance Roof - Tight or with a Space?
- 2.7 Electrical Wires
- 2.8 Hardware Needed for Installing Suretouch
- 2.9 Different Types of Membranes

---

### 3. Receiving Suretouch Materials

---

### 4. Installation of Starter Strips

- 4.1 Inside Corner
- 4.2 Outside Corner
- 4.3 Arched Opening
- 4.4 Installation on a Concrete Wall
- 4.5 Larger than 10' (3 m)

---

### 5. Installing Suretouch Polystyrene Panels: The Main Principles

- 5.1 Suretouch Polystyrene Panels: The different ways to start installing Suretouch panels
- 5.2 Durham Polystyrene Panels
- 5.3 Oxford Clay Brick and Classic Concrete Brick Polystyrene Panels

---

### 6. Installing Brick or Stone Units

- 6.1 Morency and Durham Stone
- 6.2 Oxford Clay Brick
- 6.3 Classic Concrete Brick

---

### 7. Installing Sills

- 7.1 Soldier Stones and Bricks
- 7.2 Suretouch Jamb, Sill and Keystone Accessories
- 7.3 Conventional Concrete or Other Accessories
- 7.4 Insertion of Thermo-flexible Elements

---

### 8. Installation Details

- 8.1 "J" Trim
- 8.2 Using Glue
- 8.3 Incomplete Stone or Brick Cells
- 8.4 Cutting the Suretouch Elements
- 8.5 Thermo-flexible Elements
- 8.6 Nails in Insulating Panels

---

### 9. Installation of Weepers and Expansion Joints

---

### 10. Preparing for Injecting Suretouch Mortar

---

### 11. Injecting Suretouch Mortar

- 11.1 The Various Injection Tools Available
- 11.2 Injection Methods
- 11.3 Good and Bad Injections
- 11.4 Recipe for a Suretouch Mortar Slurry
- 11.5 Square Feet Covered by 25kg of Mortar in 4 Suretouch Systems

---

### 12. Finishing the Joints

- 12.1 Finishing Tools
- 12.2 Finishing Morency and Durham Stone Joints
- 12.3 Finishing Clay Brick
- 12.4 Type of Joints
- 12.5 Cleaning

---

### 13. Problem Solving FAQs

- 13.1 Cracks in the Mortar
- 13.2 Broken Stones or Bricks
- 13.3 Replacing a Broken Stone in the Wall
- 13.4 Missing Weepers
- 13.5 Efflorescence on the Suretouch Units and Variations in Mortar Colour
- 13.6 Mixing Stone Colours

---

### 14. Conclusion

This document is a basic guide explaining the various steps for installing any Suretouch masonry system product.

*Note: To simplify the text, the word “unit” and the expression “masonry unit” are often used for “stone and brick”.*

## Important warnings (before you start)

- Get a permit from your municipality before starting work.
- **This product cannot be installed over furring strips.**
- Be sure to wear a hardhat, construction boots, gloves and safety glasses.
- Use safe work methods to prevent any accidental fall of stones or bricks that could have serious consequences. **The units inserted in the polystyrene cells are not secure until they have been pointed.** The polystyrene can only hold the units for a short time, particularly if site activity causes strong vibrations. The wall should therefore be pointed with mortar as soon as possible. Make sure that no-one (worker or other) is near an unpointed Suretouch wall.
- **To avoid accidents, it is essential that the units be glued to the polystyrene with drops of glue (without plugging the water drainage channels) in the following situations:**
  - When a unit is placed in a broken, damaged or incomplete cell;
  - Along corners,
  - When a unit spans a horizontal joint between two panels.

Glue should also be used if the small protrusions on the top of the unit are damaged.
- In this guide, the cladding is applied to a conventional wood wall frame (studs at 16 in. [400 mm] centres). Installation on any other type of structure should be adjusted accordingly and approved by an engineer.
- Attach any hooks or anchors (for a clothesline, for instance) to the structure of the house. Any deterioration caused by attaching the hook to the facing alone will not be covered by the warranty.

**For more information, go to [suretouch.ca](http://suretouch.ca) or call Suretouch at 1 888 737-6226.**

## Table of contents

### Tools and materials

• Tools	6
• Materials	6

### Preparation

• Wall alignment	7
• Stud location	7
• Foundation support	7
• Adhesive waterproofing membrane and air barrier	8
• Reference line	8
• End point	9

### Installing the polystyrene panels

• General principles for installing the panels	10
• Installing the first panel	11
• Installing the remaining panels	13
• Meeting up with the existing cladding	15
• Cutting the panels at the roof line	16
• Urethane acoustic sealant (Top of walls)	16
• Outside corners	17
• Inside corners	17
• Steel starter strip above openings	18
• Around openings	19
• «J» trim	20
• Allowing for sills	20

### Installing the masonry units

• Sills	21
• Architectural elements	21
• General principles for inserting the units	22
• Cutting the stones	24
• Inserting a stone into an incomplete cell	24
• Weepers	25
• Around openings	25
• Above Class 2 and 3 openings	26
• Soldier bricks and stones above openings	27
• Corners	28

### Pointing

• Preparing a batch of mortar	29
• Injection	30
• Finishing	30
• Brushing	31
• Cleaning	31
• Caulking	31
• Efflorescence	31

# 1. Tools and materials

## • Tools

- Utility knife
- Level
- Screw gun (preferably Impacto type)
- Circular saw
- Guillotine
- Grinder
- Pointing tools (see **Pointing** section)

## • Materials

### Included in the Suretouch system:

- Polystyrene panels
- Stones or bricks
- Mortar (must be Suretouch mortar)
- Stainless steel anchors and screws
- Galvanized steel starter strip
- Spacers
- Weepers

### Other:

- Sills, jambs, lintels, keystones, etc.
- Adhesive waterproofing membrane
- Polystyrene-compatible acoustic caulk in tubes
- "J" trim for windows
- Glue (PL Premium)
- Deck screws (ceramic-coated) (# 8 • 1½ in. to 2 in.)



Spacers



Weepers



This symbol in front of a section indicates that it applies to **stone** claddings only.



This symbol in front of a section indicates that it applies to **brick** claddings only.

The illustrations can show installation conditions for either stones or bricks. Unless otherwise indicated, the principle illustrated is the same for both types of masonry.

# 2. Preparation

## • Wall alignment

Check the alignment of the wall to be covered, as the Suretouch system is installed directly onto it. Make sure that any visible deviations, bulges or imperfections on the wall are carefully corrected. We suggest you use OSB panels.

## • Stud location

Mark the stud locations on the steel starter strip. This will ensure that the anchors are screwed into the stud, and not into a non-structural nailer.

## • Foundation support

If the foundation provides a support base of at least 3¼ in. (82 mm), it is sufficient to support the Suretouch system directly. If the support base is narrower, as is often the case in renovations, a steel starter strip will have to be added.

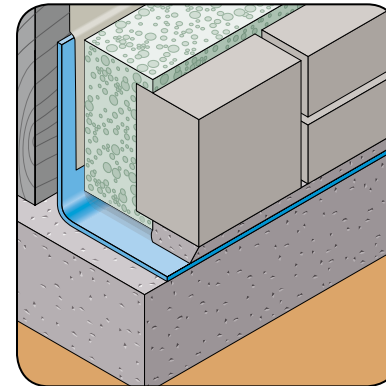

With a brick ledge of 3¼ in. or more

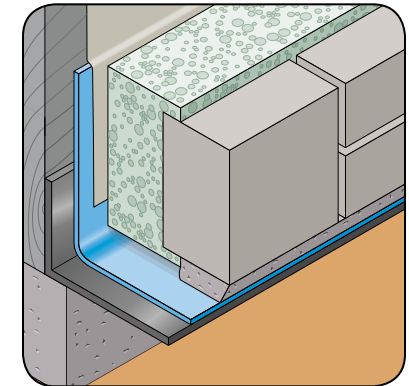

Without a brick ledge. Using Suretouch steel starter strip.

## 2. Preparation (continued)

### • Adhesive waterproofing membrane and air barrier

Place the adhesive waterproofing membrane to the foundation or steel starter strip, then overlap the air barrier and glue it to the adhesive waterproofing membrane. The air barrier should not extend onto the horizontal part of the foundation or steel starter strip.

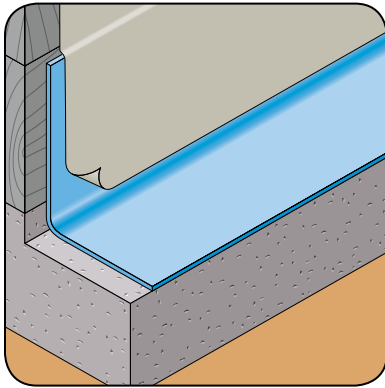

### **B** Reference line

The reference line allows first the polystyrene panels and then the bricks to be properly aligned. To establish this line, temporarily place one panel so that it is level. Leave a space between the bottom of the polystyrene panel and the foundation (or steel starter strip). This space should be approximately the same width as the joints between the bricks. Draw a level line along the top of the panel. Measure the distance between this line and the bottom of the roof truss (a). Transfer this measurement to each corner and then draw a line connecting these points on the wall to be covered, or around the perimeter of the house, if appropriate.

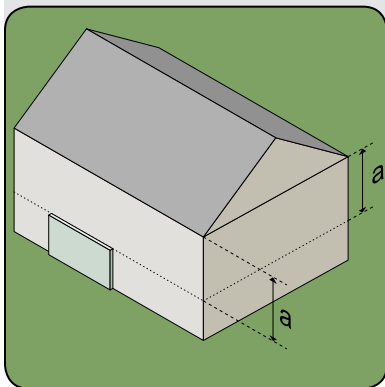

### • End point

If you plan to cover all the walls of the house, you will have to decide ahead of time on a point at which the first and last panels will meet (end point).

Choose the top of an inconspicuous door or window, perhaps on the side or back of the house. For a nicer look, you can change the installation pattern when the units are being installed by creating new cells (B) to avoid ending up with a long vertical joint (A).

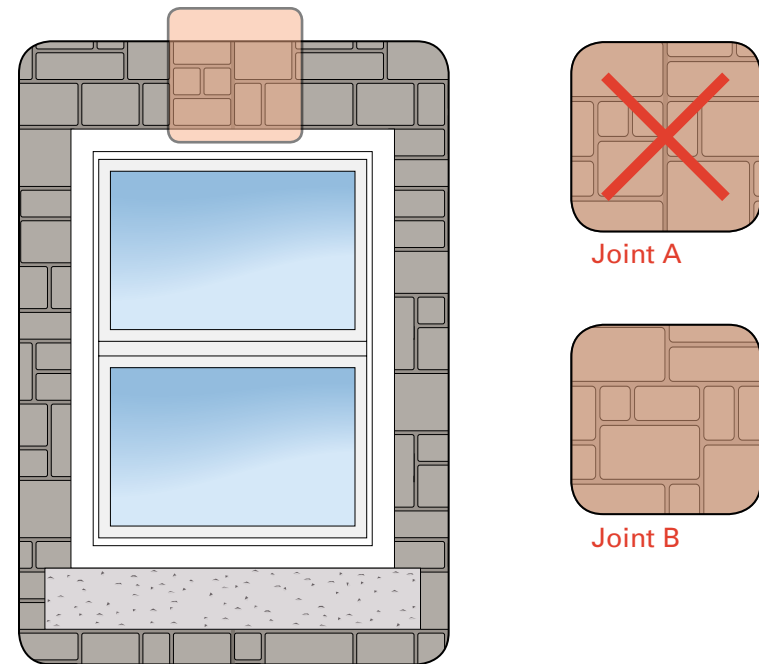

### 3. Installing the polystyrene panels

#### IMPORTANT

The Suretouch system is designed for conventional wood structures with studs spaced at 16 in. (400 mm) centres. For any other type of structure, plan the anchor arrangement in consultation with an engineer to ensure that the entire structure is solid.

**Only use Suretouch stainless steel screws and anchors and this product cannot be installed over furring strips.**

#### • General principles for installing the panels

Always install the panels from left to right.

Do not rest the panels on the steel starter strip (at the bottom of the wall and above openings). Always leave a space.

All the polystyrene must always be attached to wall studs with at least one Suretouch stainless steel anchor and screw for every 2 ft<sup>2</sup> (0.18 m<sup>2</sup>). To achieve this ratio on a structure at 16 in. (400 mm) centres, the anchors should be spaced 19 in. (485 mm) apart vertically and should all be screwed into studs. The vertical edges of the polystyrene panels do not have to be aligned with the stud centres.

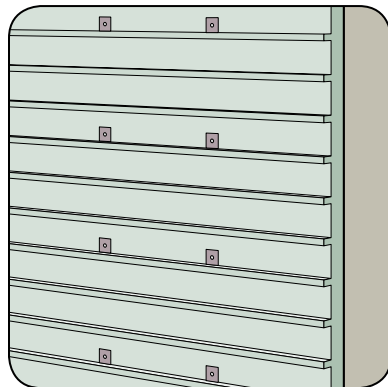
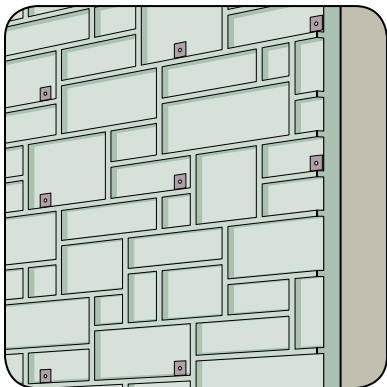

Attach the anchors at the bottom of the cell in such a way that their prongs are visible under the units once the units are inserted. These prongs will ultimately sit in the mortar joint and hold the cladding firmly to the structure.



The panels are installed vertically or horizontally, depending on the type of masonry. **The panels should always be installed in the direction indicated;** otherwise they will not hold the masonry units properly.



#### Installing the first panel

Install the first panel parallel to the reference line, leaving a space between the bottom of the panel and the foundation (or steel starter strip). This space should be the same width as the joints between the bricks.

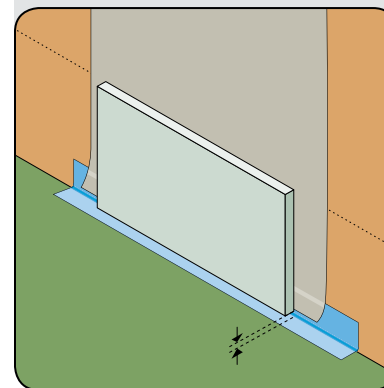

### 3. Installing the polystyrene panels (continued)

**S**

#### Installing the first panel

Install the first panel level, leaving a 3/8 in. (10 mm) space between the polystyrene panel and the foundation (or the steel starter strip).

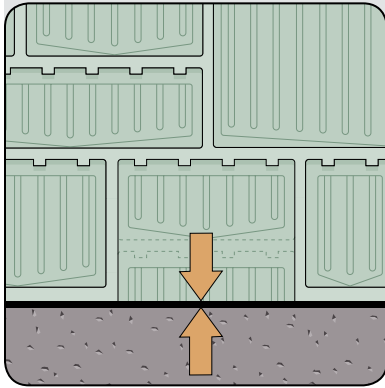

If you plan to cover all the walls of the house, the left edge of the first panel should be aligned with the predetermined end point.

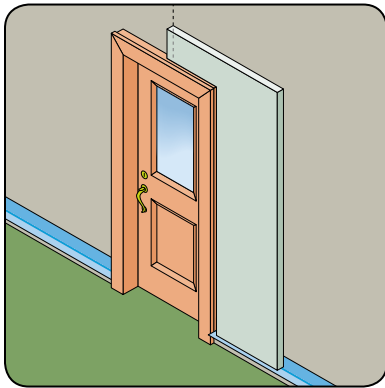

**B**

#### Installing the remaining panels

Install the panels so that their vertical joints are offset. Check the level against the reference line and make any necessary corrections.

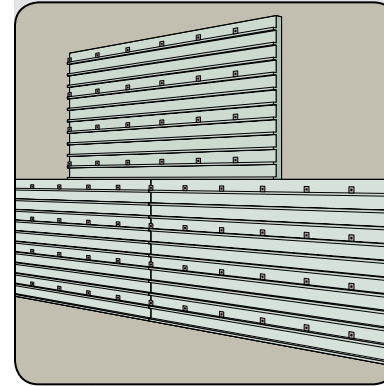

### 3. Installing the polystyrene panels (continued)



#### Installing the remaining panels

For Morency and Durham stones, the panels are offset upward, from left to right. There are reference numbers on the front and back of each panel and male/female shiplaps on the sides to facilitate installation. For more details, go to [suretouch.ca](http://suretouch.ca).

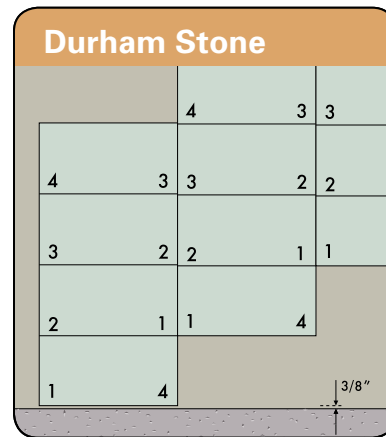
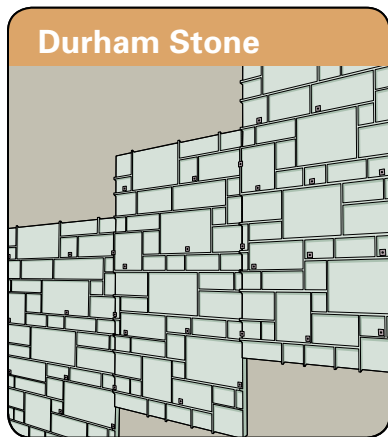
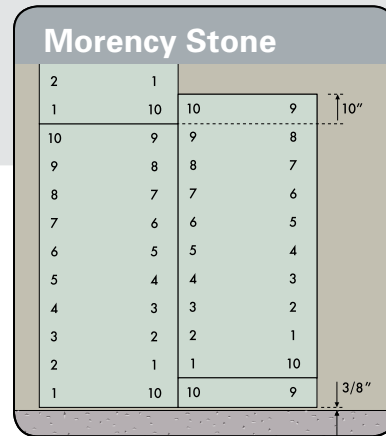
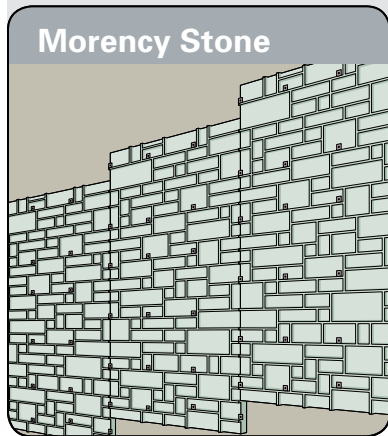

#### IMPORTANT

Always leave a space between the bottom of the panel and the horizontal part of the steel starter strip (or the foundation) at the base of the wall.

#### Meeting up with the existing cladding

When Suretouch cladding meets up with an existing cladding such as clapboard siding, you have two options.

##### Option 1

Extend the polystyrene minimum 1 ft (300 mm) around the corner and use "J" trim to hide the edge of the polystyrene. To install the polystyrene in a corner, see "outside corners", p. 17. During installation, use drops of glue to hold the corner units in place.

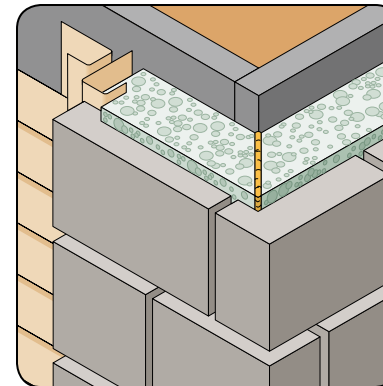

##### Option 2

Cut a 2 in. (50 mm) strip of polystyrene from the left edge of the panel. When installing the units along this edge, use drops of glue to hold them in place.

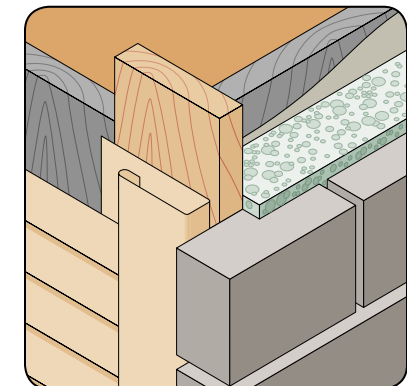
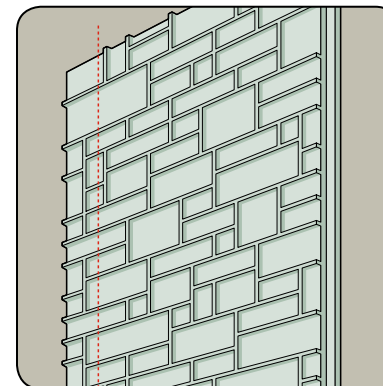



### 3. Installing the polystyrene panels (continued)

#### • Cutting the panels at the roof line

When the panels reach the top of the wall, they must be cut. Allow the panels to extend a few inches into the attic space, so that the soffits will rest against it. The cut pieces can be reused elsewhere where appropriate.

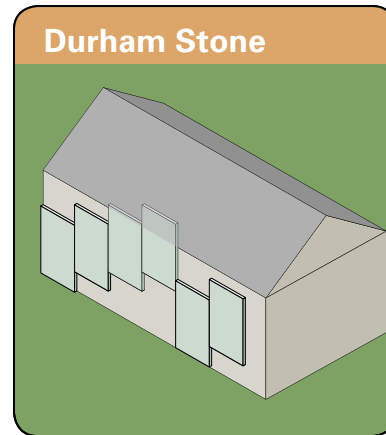
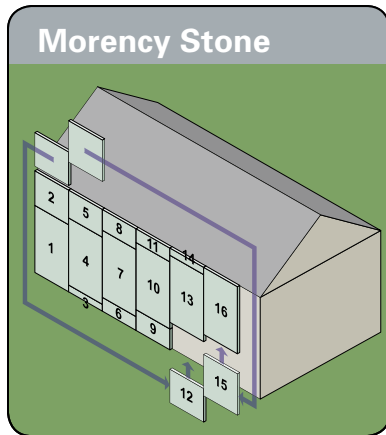

#### • Urethane acoustic sealant (Top of walls)

Just prior to installation, run a horizontal urethane acoustic sealant along the back of the top panel, about 2 in. (50 mm) below the planned soffit level. The bead will be flattened when the anchors are installed and will plug the channels on the back of the panel. This will prevent heat loss into the attic space through the chimney effect. Note that this operation is only performed on the panels at the top of the walls.

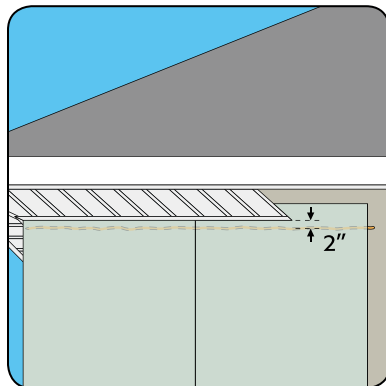

#### • Outside corners

To turn a 90° corner, make two vertical 45° cuts on a panel. The cuts must be exactly 45° for the polystyrene cells to hold the corner units firmly in place. Because the corners of a building are never perfect, the two 45° edges of the polystyrene will often not meet perfectly. Align the cells as closely as possible, and fill any spaces using minimal expansion insulating foam. Once the foam has finished expanding, cut off any excess with a utility knife. It is important to take care of the cell edges, as it will make it easier when installing masonry units. The foam not only improves insulation in the corners, it forms a continuous cell edge and solidly joins the adjacent panels.

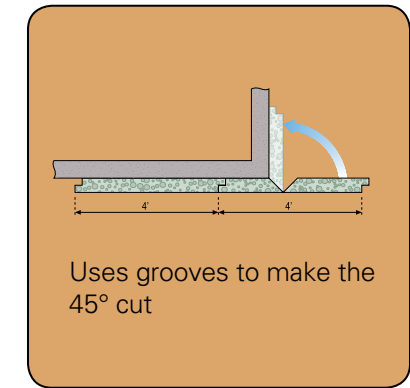
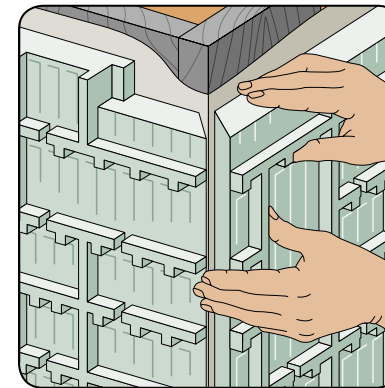

#### • Inside corners

Cut a section of panel (A) at a right angle so that it fits properly all the way to the edge of the wall. Once the panel is installed, remove 2½ in. (65 mm) of cell edge all along the corner. Fit the "B" part of the panel into the "A" part.

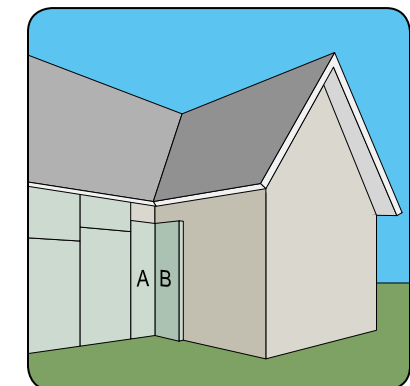
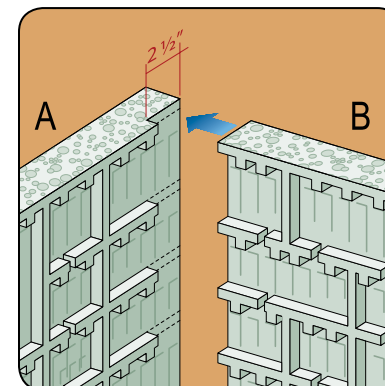

### 3. Installing the polystyrene panels (continued)

#### • Steel starter strip above openings

Always leave a minimum of 1/8 in. space above the opening.

#### • Classes of openings (doors and windows)

##### Class 1

- In a home renovation project, all openings up to 4 ft (1.2 m) wide, regardless of the number of floors

##### and/or

- In a new home project, all ground floor openings up to 4 ft (1.2 m) wide

##### Class 2

- In a new home project, openings up to 4 ft (1.2 m) wide on floors above the ground floor

##### Class 3

- For both home renovation and new home projects, any large-sized opening (garage doors, living room windows, patio doors, picture windows, etc.)

#### • Class 1

Cut a piece of Suretouch steel starter strip the length of the window and screw it to the lintel every 8 in. (200 mm).

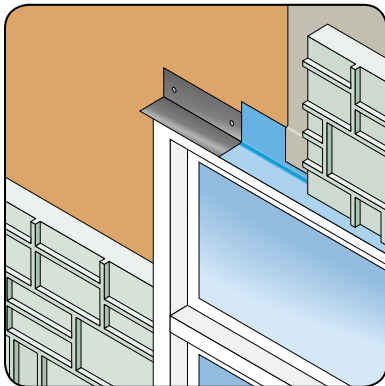

#### • Class 2

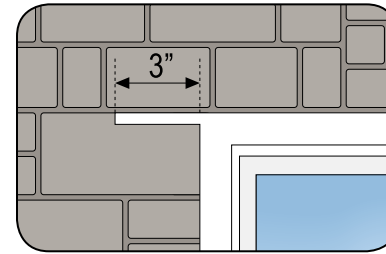

Note: In this class, plan for settling of the wood structure on the upper floors of a new home.

Cut the steel starter strip the length of the opening + 6 in. (150 mm) (3 in. on each side). Screw it to the lintel every 8 in. (200 mm).

#### • Class 3

It is very important to ensure that the lintels and steel starter strip of large openings can support the weight of the units to be installed above them. When in doubt, it is best to consult an engineer. All large openings must be braced during work to ensure that the steel starter strip does not bend under the load. The supports are removed once the mortar has cured.

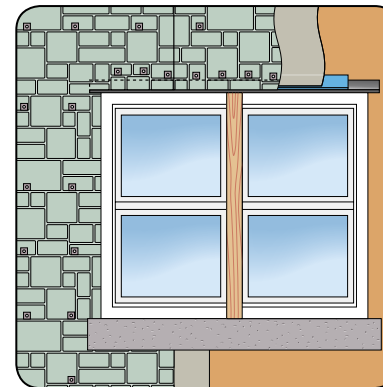

##### Notes

Never rest the steel starter strip on the frame of the opening. Leave a 1/4 in. (6 mm) space under it, to be sealed later with caulking.

Use more Suretouch anchors above Category 2 and 3 openings, about one anchor every 8 in. (200 mm) horizontally.

Leave a 3/8 in. (10 mm) air space between the bottom of the polystyrene panel and the horizontal part of the steel starter strip.

#### • Around openings

Trim the polystyrene panels flush with the frame of the opening. When installing doors and windows in new home construction, allow for the frame to protrude far enough to cover the visible edge of the polystyrene. **The frame should extend 2 to 2½ in. (about 60 mm) beyond the base wall so as to completely cover the polystyrene.**

### 3. Installing the polystyrene panels (continued)

#### • "J" trims

For renovation projects, add aluminum flashing "J" trim (standard trim available at hardware stores or bent by a tinsmith) to hide the edge of the polystyrene.

There are three steps to installing the trim.

1. Once the polystyrene panel is installed and trimmed, remove 3/4 in. (20 mm) of cell ridge on each side of the opening.
2. Make a  $\pm 1/2$  in. (12 mm) deep channel over the full height of the opening.
3. Insert the "J" trim.

The units will later rest on the trim, 1/8 in. (3 mm) toward the outside of the opening.

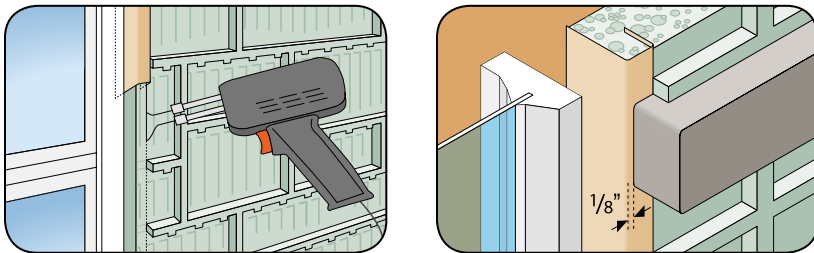

#### • Allowing for sills

At the base of a window, cut the polystyrene to create the opening required to install a sill. The dimensions of the polystyrene section to be removed are: (sill's length + 3/8 in. (10 mm) of its thickness). Run a bead of acoustic caulking the length of the polystyrene. Cut a section of steel starter strip the same length as the sill. Run a bead of acoustic caulking along the top of the back of the steel starter strip. Press the base onto the polystyrene and screw it to the structure every 8 in. (200 mm).

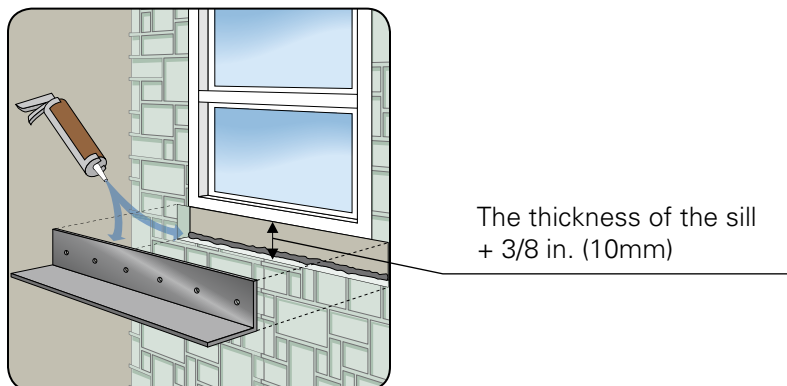

### 4. Installing the masonry units

#### • Sills

Put drops of glue on all the screw heads and screw holes of the steel starter strip installed earlier. Put 1/8 in. (3 mm) thick spacers at the bottom of the steel starter strip so that the sill slopes about 5° toward the front. Attach the sill with screws and bent metal straps.

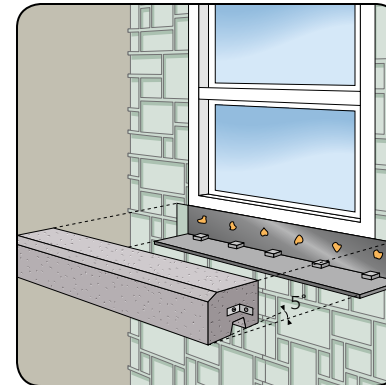

#### • Architectural elements

Install accessories (keystones, jambs, lintels, civic numbers, French corners, outlet trim, hose trim, etc.) before you install the units. These accessories are not included in the system, but can easily be installed. **Always leave a 1/8 in. (3 mm) space between the steel starter strip and an accessory above an opening. Attach accessories using screws and bent metal straps.** Take the necessary precautions if you want the accessories to extend out beyond the masonry.

## 4. Installing the masonry units (continued)

### IMPORTANT

Use safe work methods to prevent any accidental fall of stones or bricks that could have serious consequences. **Stones or bricks inserted into their polystyrene cells are not secure until they have been pointed.**

The polystyrene can only hold the units for a short period of time, especially if site activity causes strong vibrations. The wall should therefore be pointed as soon as possible. Make sure that no-one (a worker or anyone else) remains near an unpointed Suretouch wall.

**Note: Sills and architectural elements should be installed before the units.**

### • General principles for inserting the units

Brick and stone units are inserted into the polystyrene cell in the same way. First, insert the unit all the way into the top of the cell, then tilt it down and push the base of the unit into the wall.

**S**

The stones come in different shapes, each corresponding to the shape of a polystyrene cell. The order in which the units are inserted into the cells is irrelevant from a technical standpoint. Simply find a cell that is the same shape as the stone, and insert the stone.

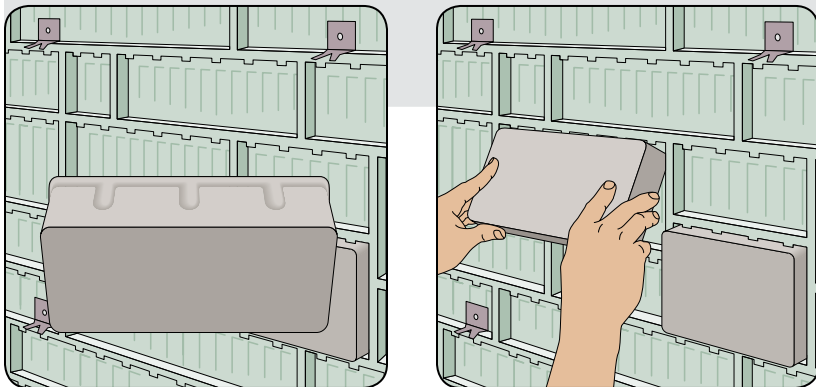

**B**

Bricks must be installed sequentially, one row at a time, from left to right, starting from the bottom up. Complete one entire row before moving up a row. **For multi-sized bricks, alternate the sizes, making sure that you never align two adjacent vertical joints .**

- To avoid accidents, it is essential that the units be glued to the polystyrene with drops of glue (without plugging the water drainage channels) in the following situations:
  - Along corners;
  - When a unit is placed in a broken, damaged or incomplete polystyrene cell;
  - When a unit spans a horizontal joint between two panels.

Glue should also be used if the small protrusions on the top of the unit are damaged.

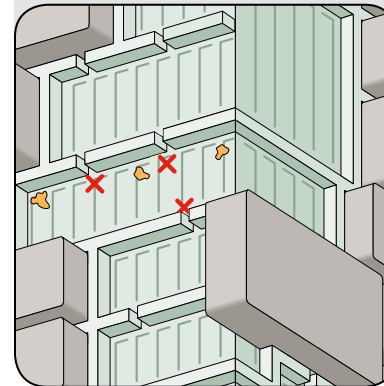

## 4. Installing the masonry units (continued)

### IMPORTANT

Allow for a mortar joint along the entire length of the base, between the bottom of the units and the top of the foundation.

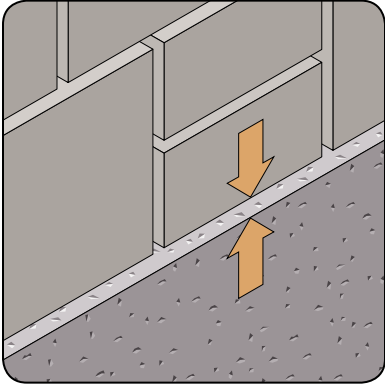

### Cutting the stones

For incomplete cells, you can usually combine two cells by breaking the edges and then use another size of stone. If this is not possible, cut the stone using a guillotine.

#### • Inserting a stone into an incomplete cell

A polystyrene cell with no bottom edge cannot hold a stone. This problem can be addressed by placing a small drop of glue in each of the upper corners of the cell, then inserting the stone while wedging it with the spacers that come in the packs of polystyrene panels. The spacers are removed during pointing.

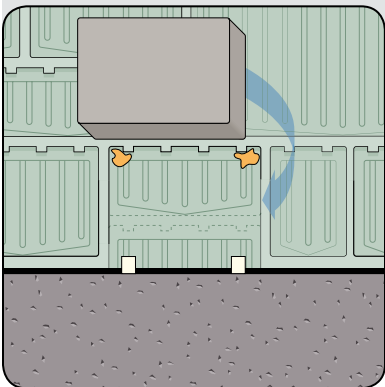

#### • Weepers

Foam cubes used to create weep holes (for drainage) and air vents (to equalize the pressure behind the cladding) should be placed **at the base of the walls and top of openings**, at least 24 in. (600 mm) but not more than 30 in. (750 mm) apart. Install these cubes between the base of the masonry and the foundation (or at the steel starter strip), in front of the cell's weephole.

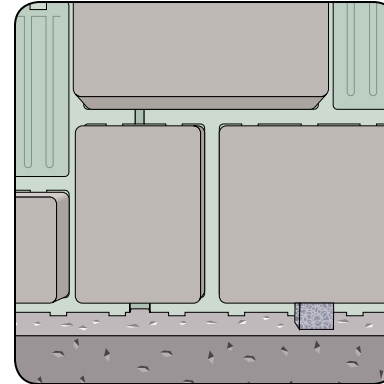

#### • Around openings

There are two possible options, depending on whether or not you are using Suretouch architectural elements (jambs, lintels, keystones).

##### Option 1 – With Suretouch accessories

Cut the units around the openings, leaving enough space for a mortar joint between the masonry unit and the jamb (or lintel, keystone, etc.).

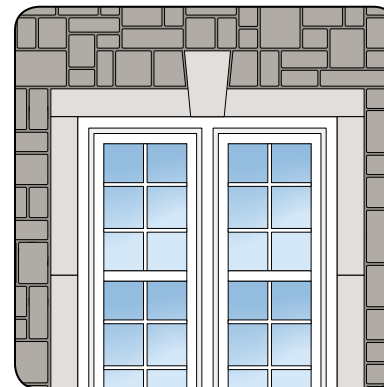

## 4. Installing the masonry units (continued)

### Option 2 – No accessories

Cut the excess part of the units that will line the sides and top of the opening. Always cut the side away from the opening so that the side that is visible is the factory (uncut) side of the unit.

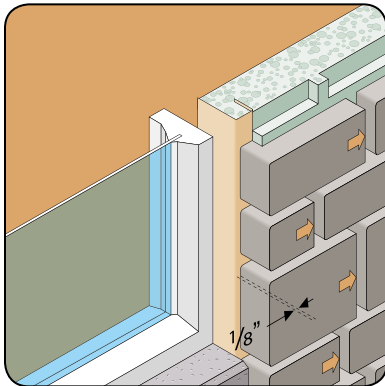

### • Above Class 2 and 3 openings

Above Class 2 and 3 openings, trim the corner iron (steel starter strip) at each end and make a saw cut in the units that will support it.

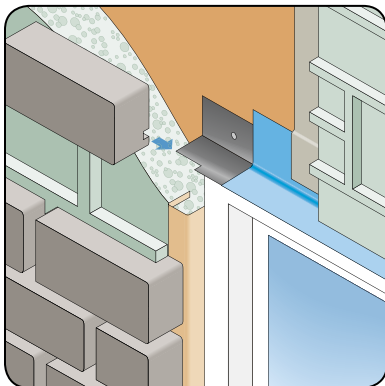

### **B** Soldier bricks above openings

Lay bricks above openings in the soldier position. Cut the units to the right size, allowing for a 1/8 in. (3 mm) space between the bottom of the units and the steel starter strip. Remove the polystyrene ridges to allow the bricks to be inserted. Use drops of glue and spacers to hold these bricks in place.

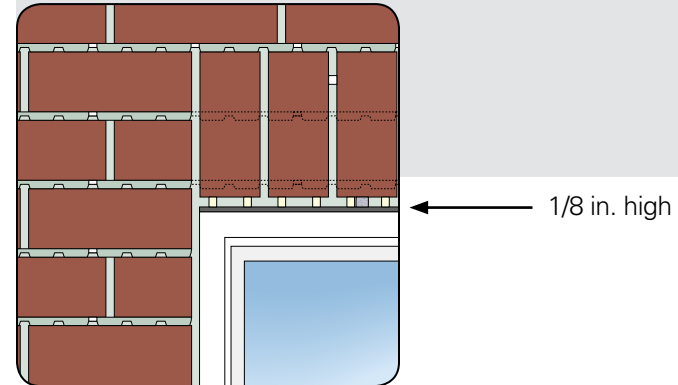

### **S** Soldier stones around openings

**Above**  
Break the polystyrene ridges above the opening over a height of 7½ in. (190 mm). Pre-glue (with PL Premium) the 7¼ in. (185 mm) in soldier stones onto a lightweight concrete panel (1/2 in. x 6 in. x the width of the opening). Once the glue is completely dry, attach the unit in the lintel, 1/8 in. (3 mm) above the steel starter strip, using two 3-in. (75 mm) decking screws per vertical joint, with one of the two only partially sunk to act as a metal strap.

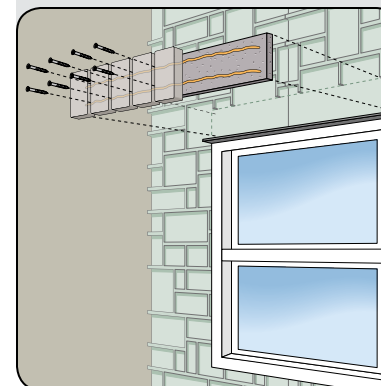

### **On the sides**

Proceed in the same manner, leaving 1/8 in. (3 mm) between the sides of the stones and the opening.

## 5. Pointing

### **S** Corners

To avoid having stones that are too small, break some of the vertical sections of the polystyrene cell edges (1) to create new joints and/or new stone shapes. Use a stone cutter. Always break the stone on the side away from the corner (2) so that the unbroken side of the stone (3) is the one that shows.

Place a drop of glue (PL Premium) in the upper corners of the cells (4) for all corner stones.

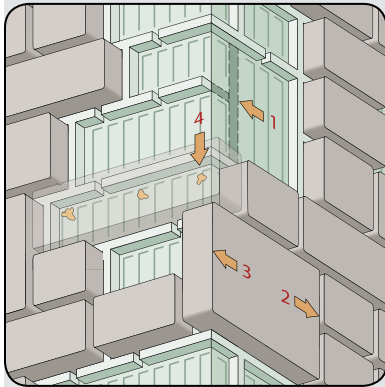

**Important: We never install a unit that is smaller than the smallest unit in the pallet.**

Interlace corner stones as you go up by alternating:

- one stone recessed 3/4 in. (20 mm) in from the corner (A)

**with**

- one stone protruding 1 3/4 in. (45 mm) out from the corner (B).

This produces a 3/4 in. (20 mm) joint between two stones at 90°. **This technique works for both inside and outside corners.** Occasionally, you may have to deviate from this alternating pattern because of a conflict in stone height (B vs C and D).

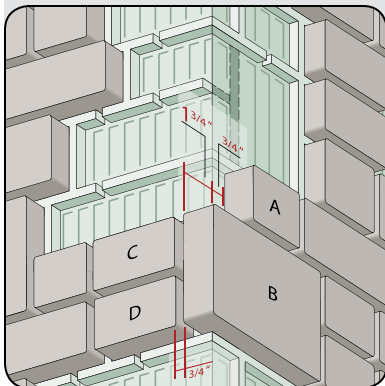

### **IMPORTANT**

The Suretouch system must be pointed with Suretouch mortar. Other mortars are not suitable, and can alter the system's performance.

### • **Mortar tools and accessories**

- Whitewash brush
- Wooden dowel 1/4 in. (6 mm) larger in  $\varnothing$  than the width of the mortar joint
- Cat's tongue trowel
- Mortar bit (use with power drill to mix)
- Containers to measure the water and additives
- Manual injection gun **and/or** Grout Bag, Quick-point, Twist & grout

**Note: Professionals inject mortar using a special pump that covers large surfaces quickly, but requires proper training and practice.**

### • **Preparing a batch of mortar**

Mix a bag of mortar properly. The recipe is 4.5 litres (about one gallon) of water for each 25 kg bag. This can be adjusted later if the mixture is too thick or too runny.

### • **Important precautions**

- Protect the mortar from moisture from the moment it arrives.
- A batch of mortar is only good for about 1 1/2 hours at about 20° C.
- Useful life varies depending on the outside temperature.
- Over 28° C, a retarder is advisable.
- Under 10° C, an accelerator is suggested.
- Use cold water in summer and hot water in cold weather.
- Place the mortar and equipment in a dry, shady spot.
- Wet down the wall five minutes before pointing. In hot weather, drench the units well.
- It is preferable to inject the mortar when the wall is in the shade.
- It will be advisable to try the mortar with the exceeding material.
- If you consider to apply the mortar in the Suretouch wall two weeks after installing the stones, we suggest to apply glue behind each unit. In case you require additional information, please contact the Suretouch technical service.

## 5. Pointing (continued)

### • Injection

Before pointing, make sure that all the spacers have been removed **and the weeps are in place**. Injecting mortar takes practice. Take your time to fill the joints completely, making sure to fill the cavities thoroughly and embed the “prongs” of the Suretouch anchors. Don’t waste your time trying to fill the vertical slots at the bottom of the polystyrene cells with mortar. These slots allow any water or condensation that penetrates the mortar joints to drain. Until they are finished, mortar joints should look like rough welding joints.

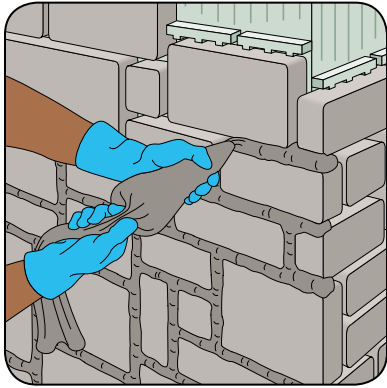

### • Finishing

Finishing mortar is an art. To obtain a nice finish, it is important to finish the joint when the mortar is somewhat cured but not too dry. Take the weather into account, as it influences curing time. Apply firm pressure to the joint using a wooden dowel to ensure that the mortar adheres properly to the surface of the unit. This gives a smooth finish to the joint. Around openings, use a cat’s tongue trowel; this produces a joint that is flat rather than concave.

**Take care to obtain a uniform, granular finish.**



### • Brushing

Before brushing, make sure the mortar is hard enough that it will not dirty the stones or bricks. Use a whitewash brush. Brush in such a way that the particles come off without dirtying the brush and spreading mortar all over the wall. Brushing should be done the same day as injection. It is better to brush mortar that is slightly too hard than too soft.



### • Cleaning

If any mortar residue remains on the stones once the mortar has dried, use a gentle masonry cleaner according to the manufacturer’s instructions. Do not use a pressure washing system to wash the cladding. We recommend to clean the Suretouch units by sandblasting them.

### • Caulking

Once all the mortar on the wall has dried completely, the caulking specialist should run a caulk bead around all the openings.

### • Efflorescence

In the weeks and months after installation, efflorescence may occur (white salt on the surface of the stones). This is normal, and disappears with time. However, it can be cleaned by brushing the wall with a soft-bristle brush dipped in a gentle masonry cleaner, after first spraying the wall with water. Rinse by spraying gently with a garden hose. Do not use a pressure washing system.





Institute for Research  
in Construction  
National Research Council Canada  
evaluation # : CCMC 13302-R

**Suretouch.**  
by Permacon

1 888 737-6226  
[suretouch.ca](http://suretouch.ca)

8145 Bombardier Street  
Montréal (Québec) H1J 1A5

## **SURETOUCH**

Patented in Canada, United States and Europe

Revision: May 2013

This guide is valid in Canada only